

PBXGB-AA/CA PCI Graphics Option

Owner's Guide

Order Number: EK-PCIGR-OG. A01

First Printing, December 1995

Digital Equipment Corporation makes no representations that the use of its products in the manner described in this publication will not infringe on existing or future patent rights, nor do the descriptions contained in this publication imply the granting of licenses to make, use, or sell equipment or software in accordance with the description.

© Digital Equipment Corporation 1995. All Rights Reserved.
Printed in U.S.A.

The following are trademarks of Digital Equipment Corporation: DEC, Digital, Digital Open3D, Digital UNIX, OpenVMS, VAX DOCUMENT, and the DIGITAL logo.

Microsoft is a registered trademark, and Windows NT is a trademark of Microsoft Corporation.

All other trademarks and registered trademarks are the property of their respective holders.

S3087

This document was prepared using VAX DOCUMENT Version 2.1.

FCC Notice:

FCC ID: AO9-PBXGC and AO9-PBXGD

This device complies with Part 15 of the FCC Rules. Operation is subject to the following conditions:

1. This device may not cause harmful interference, and
2. This device must accept any interference received, including interference that may cause undesired operation.

This equipment has been tested and found to comply with the limits for a Class B digital device, pursuant to Part 15 of the FCC Rules. These limits are designed to provide reasonable protection against harmful interference in a residential installation. Any changes or modifications made to this equipment may void the user's authority to operate this equipment.

This equipment generates, uses, and can radiate radio frequency energy and, if not installed and used in accordance with the instruction manual, may cause harmful interference to radio communications. However, there is no guarantee that interference will not occur in a particular installation. If this equipment does cause harmful interference to radio or television reception, which can be determined by turning the equipment off and on, the user is encouraged to try to correct the interference by one or more of the following measures:

- Reorient or relocate the receiving antenna.
- Increase the separation between the equipment and receiver.
- Connect the equipment into an outlet on a circuit different from that to which the receiver is connected.
- Consult the dealer or an experienced radio/TV technician for help.

The video cable port should be connected with only a shielded data cable with an integrated ferrite bead over the cable. If this port is connected with a cable *without* such a ferrite bead, additional ferrite beads shall be clamped over the cable next to the cable connector near the system unit.

**DOC
Compliance
Statement**

This digital apparatus does not exceed the Class B limits for radio noise emissions from digital apparatus set out in the Radio Interference Regulations of the Canadian Department of Communications.

**MDC Avis De
Conformation**

Le present appareil numerique n'emet pas de bruits radioelectriques dépassant les limites applicables aux appareils numeriques de Classe B prescrites dans le Reglement sur le brouillage radioelectriques edicte par le ministere des Communications du Canada.

EMI

This product complies with the following domestic and international standards:

- Domestic: Complies with FCC Part 15, Class B.
- International: Complies with CISPR22 (EN5502 [European Norm]) Class B.

VCCI

この装置は、第一種情報装置（商工業地域において使用されるべき情報装置）で商工業地域での電波障害防止を目的とした情報処理装置等電波障害自主規制協議会（VCCI）基準に適合しております。

従って、住宅地域またはその隣接した地域で使用すると、ラジオ、テレビジョン受信機等に受信障害を与えることがあります。

取扱説明書に従って正しい取り扱いをして下さい。

Contents

Guide Overview	1
Purpose	1
Contents	1
Conventions	2
Module Overview	3
Description	3
Version Information	3
Software	4
Limitations	4
Option Features	5
Frequency Switch	7
Description	7
Switch Settings	7
Module Installation	9
Procedure	9
Confirming Proper Installation	15
Procedure	15
Troubleshooting	15
Stereo Viewing	16
Description	16
Stereo Cable	16
Stereo Monitor	16
Appendix A — Video Timing	17
Appendix B — Module Specifications	20
Physical Specifications	20
Environmental Specifications	20
Power Consumption	20
Video Output Characteristics	21
Stereo Output Characteristics	21
Appendix C — Cabling Information	22
Cable Information	22
Appendix D — For Digital Service Use	23
Introduction	23

FRU/Order Numbers	23
-------------------------	----

Index

Figures

1	PBXGB-AA Graphics Option Module.....	5
2	PBXGB-CA Graphics Option Module.....	6
3	VGA Enable/Disable Settings—2 MB Module	11
4	VGA Enable/Disable Settings—16 MB Module	11
5	Installation of 2 MB Module	12
6	Installation of 16 MB Module	13

Tables

1	Module Versions	3
2	Compatible Software Versions	4
3	PBXGB-AA Module Features	5
4	PBXGB-CA Module Features	6
5	Switch Settings	8
6	VGA Enable/Disable and Alias Jumper Settings	10
7	Video Monitor Timing I	18
8	Video Monitor Timing II.....	19
9	PBXGB-AA/CA PCI Graphics Option Module Weight and Dimensions	20
10	PBXGB-AA/CA PCI Graphics Option Module Environmental Specifications	20
11	Video D-Sub Connector Pinout.....	21
12	Stereo Output Characteristics	21
13	Cable Options	22
14	Module FRUs	23

Guide Overview

Purpose

This guide provides general information on the PBXGB-AA/CA graphics option modules. This information is independent of the hardware platform. For specific information regarding your hardware platform, refer to your system documentation.

The components on the PBXGB-AA/CA graphics option modules are Energy Star ready.

Contents

The following information is included in this guide:

- Module description
- Module installation
- Confirming proper installation
- Stereoscopic viewing
- Video timing—frequency switch settings
- Module specifications
- Cabling information
- Field replaceable unit (FRU) order numbers

Guide Overview

Conventions

The following conventions are used in this guide:

- | | |
|------------------|------------------------------------------------------------------------------------------------|
| CAUTION | Cautions provide information to prevent damage to equipment or software. Read these carefully. |
| Important | Important notations provide information to allow your system to work properly. |
| Note | Notes contain additional information that you should be aware of. |

Module Overview

Description The PBXGB-AA/CA graphics option modules are PCI local bus options that generate high-resolution, 2- and 3-dimensional color graphics. Application programs can utilize these graphics to render mechanical and electrical CAD, molecular modeling, scientific visualization, simulation, animation, and other graphical information.

Version Information Table 1 provides information about this version of the PBXGB-AA/CA graphics option modules.

Table 1 Module Versions

Order Number	Planes	Memory
PBXGB-AA	8	2 MB
PBXGB-CA	24Z	16 MB

Each order includes the following items:

- PBXGB-xx Option Module
- *PBXGB-AA/CA PCI Graphics Option Owner's Guide*
- *Graphics Support Services Software Version 3.0 for Microsoft Windows NT Installation and User Guide*
- Antistatic wriststrap
- Ferrite bead assembly

Module Overview

Software

The PBXGB-AA/CA graphics option modules are compatible with the minimum software version levels shown in Table 2.

Table 2 Compatible Software Versions

Designation	Digital Open3D	Digital UNIX	OpenVMS Alpha	Microsoft Windows NT	Graphics Support Services Software
PBXGB-AA	V3.2	V3.2c	V6.2	V3.51	V3.0
PBXGB-CA	V3.2	V3.2c	V6.2	V3.51	V3.0

Limitations

The configuration of a multihead system requires operating system support. Refer to your operating system documentation, the *Graphics Support Services Software Version 3.0 for Microsoft Windows NT Installation and User Guide*, and the Digital Open3D software release notes, for information.

In a multihead system, only **one** graphics module can have VGA enabled.

Option Features

The PBXGB-AA graphics option module is shown in Figure 1. Table 3 describes the features.

Figure 1 PBXGB-AA Graphics Option Module

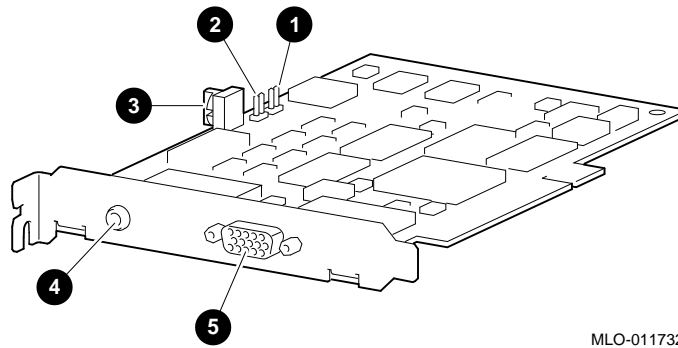

MLO-011732

Table 3 PBXGB-AA Module Features

Reference Number	Description
①	VGA enable/disable jumper pins
②	Alias jumper pins
③	Rotary video selection frequency switch
④	Stereoscopic cable port, 3.5 mm (0.18 in.) audio jack connector
⑤	Video cable port, 15-pin D-sub connector

Module Overview

The PBXGB-CA module is shown in Figure 2. Table 4 describes the features.

Figure 2 PBXGB-CA Graphics Option Module

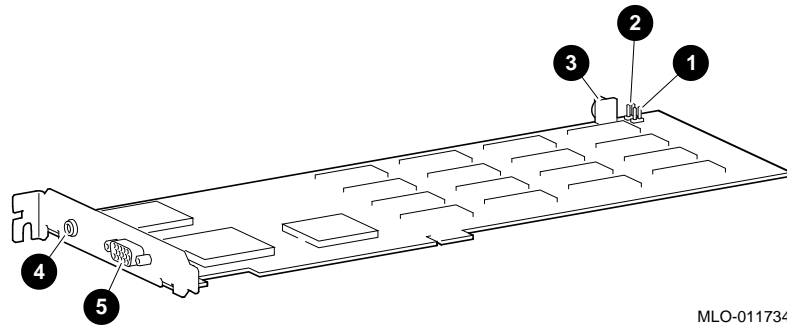

MLO-011734

Table 4 PBXGB-CA Module Features

Reference Number	Description
①	VGA enable/disable jumper pins
②	Alias jumper pins
③	Rotary video selection frequency switch
④	Stereoscopic cable port, 3.5 mm (0.18 in.) audio jack connector
⑤	Video cable port, 15-pin D-sub connector

Frequency Switch

Description Each module has a rotary-style switch with which to select the default frequency and resolution of the video signal that the module produces.

Important

The frequency switch settings listed in Table 5 are not used on systems running the Microsoft Windows NT operating system. See the *Graphics Support Services Software Version 3.0 for Microsoft Windows NT Installation and User Guide* for information on how to set your module to a correct resolution and refresh rate.

Switch Settings The installed orientation of a module varies from system to system; therefore, set the rotary frequency switch to the proper setting prior to installation of the module. Table 5 lists the PBXGB-AA/CA graphics option module switch settings.

Note

The switch setting is not dynamic and is read-only upon initialization, power-up, or system reset.

Frequency Switch

Table 5 Switch Settings

Switch Setting	Pixel Frequency (MHz)	Monitor Resolution	Refresh Rate (Hz)
0	130.808	1280x1024	72
1	119.85	1280x1024	66
2	108.21	1280x1024	60
3	104.02	1152x900	72
4	175.50	1600x1200 ¹	65
5	75.02	1024x768	70
6	74.39	1024x768	72
7	69.22	1024x864	60
8	64.99	1024x768	60
9	50.35	800x600	72
A	40.01	800x600	60
B	31.50	640x480	72
C	25.18	640x480	60
D	135.00	1280x1024	75
E	110.00	1280x1024	60
F	202.50	1600x1200 ¹	75

¹PBXGB-CA 16 MB module only.

Module Installation

Procedure

The installation of a PBXGB-AA/CA graphics option module can be accomplished in a few easy-to-do steps. Each step presumes that you are familiar with your hardware platform. For specific information regarding your hardware platform, refer to your system documentation.

1. Turn off the system and any external devices. Disconnect any external devices and cables, and unplug the power cord from the wall outlet.
2. Remove the system unit cover, and unscrew and remove the metal filler plate that may be present for the PCI slot that you have selected. Save the screw that secured the metal filler plate; you will need this screw later to secure the adapter to the enclosure.
3. Set the frequency switch using the video timing values in Table 5 as reference. Skip this step on Microsoft Windows NT systems.

CAUTION

To avoid damage to the module from static discharge, wear the antistatic wriststrap (part number 12-36175-01) when handling the module. Instructions for use are on the strap's envelope.

Module Installation

- To enable (or make active), or disable aliasing and the use of the VGA chip, set the VGA and alias jumpers correctly.

Important

There can be only one VGA-enabled device in a system.

Use the jumper setting information in Table 6, Figure 3, and Figure 4 as a guide to setting the jumpers. Note the key below the table.

Table 6 VGA Enable/Disable and Alias Jumper Settings

Reference Number	Number of Modules	Alias Jumper	VGA ¹ Jumper
21064 Processor (EV4)			
❶	Single module (primary display)	Off	On
❷	Second (additional modules)	Off	Off
21164 Processor (EV5)			
❸	Single module (primary display)	On	On
❹	Second (additional modules)	On	Off

¹The module label reads VGAEN.

Figure key:

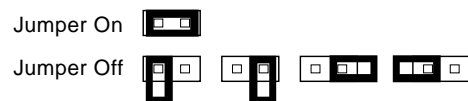
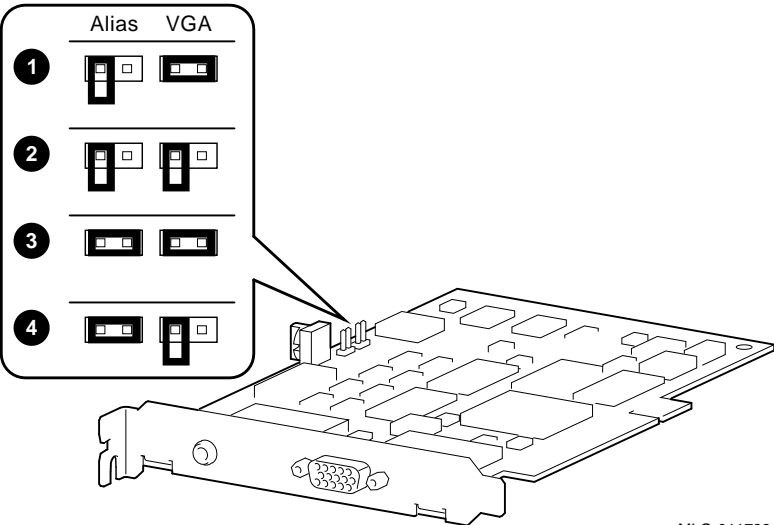
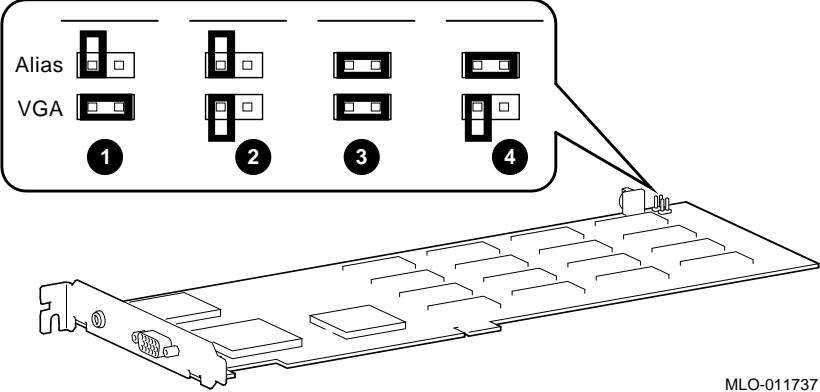

Figure 3 VGA Enable/Disable Settings—2 MB Module



MLO-011733

Figure 4 VGA Enable/Disable Settings—16 MB Module



MLO-011737

Module Installation

5. Complete the installation by following these steps:
 - ⇒ Step 1: Insert the PBXGB-AA/CA graphics option module into the option slot. See Figure 5 and Figure 6, reference numbers ❶ and ❸.
 - ⇒ Step 2: Push the adapter firmly into the socket. Insert the screw (removed from metal filler plate in an earlier step) and secure the module to the enclosure. See Figure 5 and Figure 6, reference number ❷.

Figure 5 shows the 2 MB option module being installed.

Figure 5 Installation of 2 MB Module

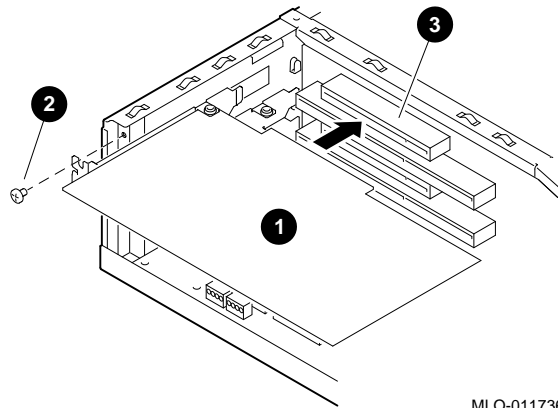

MLO-011736

Figure 6 shows the 16 MB option module being installed.

Figure 6 Installation of 16 MB Module

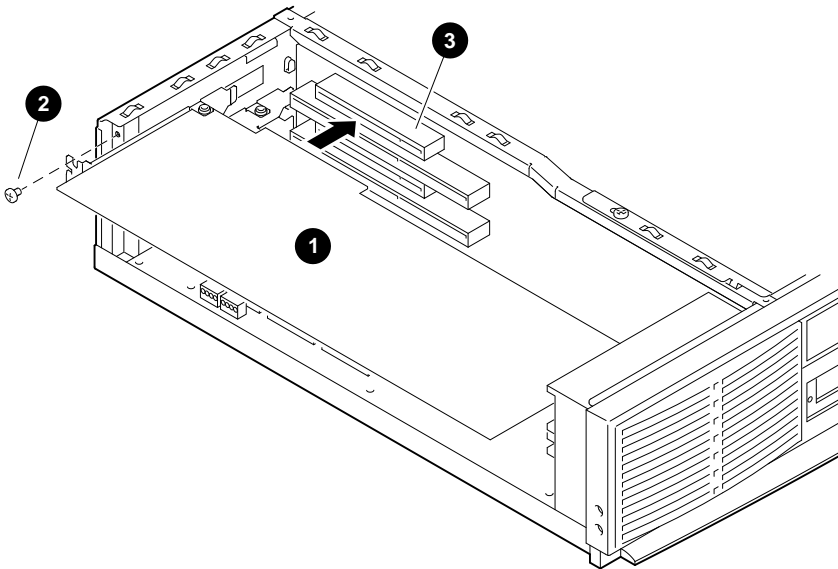

MLO-011735

Note

For graphics to appear from left to right in a multihead configuration, the leftmost monitor must be attached to the graphics module in the highest PCI slot, the next monitor to the right must be connected to the second highest graphics module, and so on.

6. Replace and secure the cover to the system unit. Attach all external devices and cables that were previously removed.

Module Installation

7. Connect the video cable to the video cable port. The video cable port is reference number ⑤ in Figure 1 and Figure 2.

Important

The video cable should be connected with only a shielded data cable with an integrated ferrite bead over the cable. If this port is connected with a cable *without* such a ferrite bead, then clamp the snap-on ferrite bead provided in your parts kit on the video cable next to the cable connector near the system unit.

8. Connect the optional stereoscopic cable to the stereo cable port. The stereo cable port is reference number ④ in Figure 1 and Figure 2.
9. Connect your video monitor as described in your system documentation.
10. Plug the power cord into the wall outlet. Turn on the external devices and the system.

Confirming Proper Installation

Procedure

To confirm that the module is installed properly, perform the following steps:

1. Turn on the monitor and any other devices connected to the system unit.
2. Turn on the system unit.
3. Verify that the console display is available and legible on the monitor screen.

Troubleshooting

If the console display *does not* appear on the monitor screen, perform the following steps:

1. Verify that the power cord for the system and video monitor, and all related devices, are plugged into a live wall outlet and that all devices are on.
2. Ensure that the video and optional stereoscopic cables and connections are secure.
3. Verify that the video cable is properly secured to the video cable port and video monitor.
4. Verify that the module is seated correctly in the PCI slot.
5. Verify that the monitor can handle the resolution and refresh rate. For Windows NT systems, refer to your *Graphics Support Services Software Version 3.0 for Microsoft Windows NT Installation and User Guide* for information. And, see Appendix A — Video Timing for more information.
6. Verify that the video monitor brightness and contrast controls are properly set.
7. Verify that the VGA and alias jumpers are set as described in Table 6, and shown in Figure 3 and Figure 4.

If a problem persists, contact your Digital service representative.

Stereo Viewing

Description StereoGraphics, a leading manufacturer of true stereoscopic viewing systems, produces equipment that allows stereo viewing applications to work with your PBXGB-AA/CA graphics option module.

For more information, contact:

StereoGraphics
2171 East Francisco Boulevard
San Raphael, California 94901
U.S.A.
Telephone: (415) 459-4500
FAX: (415) 459-3020

Stereo Cable A special 3-meter (10-foot) stereo cable is required for the PBXGB-AA/CA graphics option module. The StereoGraphics order number for this cable is DEC 69990 and has the following description:
DEC EMITTER CABLE MINI-STEREO TO BNC MST-BNC.

Stereo Monitor Stereo viewing requires that the video monitor support a special stereo frequency mode. The VRC21 video monitor supports this stereo frequency mode as well as video monitors available from other vendors.

Appendix A — Video Timing

Table 7 and Table 8 describe video timing parameters. The top row in each table lists the PBXGB-AA/CA graphics option module frequency switch settings.

Appendix A — Video Timing

Table 7 Video Monitor Timing I

Frequency Switch Setting	0	1	2	3	4	5	6	7
Pixel Clock Frequency	130.808	119.84	108.18	104.00	175.50	75.00	74.37	69.20
X Addressability	1280	1280	1280	1152	1600	1024	1024	1024
Y Addressability	1024	1024	1024	900	1200	768	768	864
Vertical Refresh (Hz)	72	66	60	72	65	70	72	60
Horizontal Frequency (KHz)	76.77	70.33	63.34	69.15	75.00	56.48	57.38	54.05
Horizontal Front Porch (μ s)	0.24	0.27	0.41	0.62	0.198	0.32	0.22	0.17
H. Synchronous Time (μ s)	1.22	1.34	1.70	1.08	1.185	1.81	1.72	1.85
H. Back Porch (μ s)	1.77	1.94	1.85	1.69	2.074	1.92	1.72	1.68
H. Blanking (μ s)	3.24	3.54	3.96	3.38	–	4.05	3.66	3.70
H. Period (μ s)	13.03	14.22	15.79	14.46	–	17.71	17.43	18.50
H. Active (μ s)	9.79	10.68	11.83	11.08	–	13.65	13.77	14.80
V. Front Porch (μ s)	0.04	0.42	0.05	0.09	0.013	0.05	0.02	0.00
V. Synchronous Time (μ s)	0.04	0.04	0.05	0.14	0.040	0.11	0.10	0.06
V. Back Porch (ms)	0.43	0.47	0.41	0.64	0.613	0.51	0.38	0.63
V. Blanking (ms)	0.51	0.55	0.51	0.87	–	0.67	0.51	0.68
V. Active (ms)	13.28	14.48	16.17	13.02	–	13.60	13.38	15.98
V. Period (ms)	13.78	15.03	16.67	13.88	–	14.27	13.89	16.67
Pixel Period (ns)	7.64	8.34	9.24	9.62	–	13.33	13.45	14.45

Table 8 Video Monitor Timing II

Frequency Switch Setting	8	9	A	B	C	D	E	F
Pixel Clock Frequency	65.00000	50.00000	40.00000	31.50000	25.17500	135.268	110.00	202.50
X Addressability	1024	800	800	640	640	1280	1280	1600
Y Addressability	768	600	600	480	480	1024	1024	1200
Vertical Refresh (Hz)	60	72	60	72	60	75	60	75
Horizontal Frequency (KHz)	48.36	48.08	37.88	37.86	31.47	82.08	–	93.75
Horizontal Front Porch (μ s)	0.86	1.12	1.00	0.76	0.64	0.591	–	0.158
H. Synchronous Time (μ s)	0.99	2.40	3.20	1.27	3.81	0.946	–	0.948
H. Back Porch (μ s)	3.08	1.28	2.20	4.06	1.91	1.183	–	1.659
H. Blanking (μ s)	4.92	4.80	6.40	6.10	6.36	2.7205	–	–
H. Period (μ s)	20.68	20.80	26.40	26.41	31.77	12.163	–	–
H. Active (μ s)	15.75	16.00	20.00	20.32	25.42	9.4627	–	–
V. Front Porch (μ s)	0.15	0.77	0.03	0.24	0.32	0.001	–	0.011
V. Synchronous Time (μ s)	0.19	0.13	0.11	0.08	0.06	0.0487	–	0.032
V. Back Porch (ms)	0.54	0.48	0.61	0.74	1.05	0.6335	–	0.491
V. Blanking (ms)	0.87	1.37	0.74	1.06	1.43	0.6823	–	–
V. Active (ms)	15.88	12.48	15.84	12.68	15.25	12.4756	–	–
V. Period (ms)	16.75	13.85	16.58	13.74	16.68	13.1579	–	–
Pixel Period (ns)	15.38	20.00	25.00	31.75	39.72	–	–	–

Appendix B — Module Specifications

Physical Specifications

The physical specifications of the modules are listed in Table 9.

Table 9 PBXGB-AA/CA PCI Graphics Option Module Weight and Dimensions

Module	Weight	Length	Width	Height
PBXGB-AA module	132 g (4.65 oz)	112.09 mm (4.413 in.)	106.68 mm (4.2 in.)	144.05 mm (.567 in.)
PBXGB-CA module	266.72 g (8.0 oz)	254 mm (10 in.)	106.68 mm (4.2 in.)	144.05 mm (.567 in.)

Environmental Specifications

The environmental specifications of the modules are listed in Table 10.

Table 10 PBXGB-AA/CA PCI Graphics Option Module Environmental Specifications

Temperature range	10°C to 40°C (50°F to 104°F)
Temperature change rate	11°C/hr (20°F/hr) maximum
Relative humidity	5% to 95% noncondensing
Maximum wet bulb temperature	28°C (82°F)
Minimum dew point	2°C (36°F)
Altitude	2,400 m (8,000 ft) at 36°C (96°F)

Power Consumption

Power consumption for the PBXGB-AA/CA graphics option module at 75 MHz is 2.2—3.3 A.

Video Output Characteristics

The PBXGB-AA/CA graphics option modules use an industry-standard 15-pin D-sub connector. The connector passes the three analog RED, GREEN and BLUE video signals, as well as vertical sync, horizontal sync, and DDC. Table 11 lists this information.

Table 11 Video D-Sub Connector Pinout

1	Red
2	Green
3	Blue
4	No connection
5	Ground
6	Red ground
7	Green ground
8	Blue ground
9	No connection
10	Ground
11	No connection
12	Display Data Channel (DDC)
13	Horizontal sync
14	Vertical sync
15	No connection

Stereo Output Characteristics

The stereo viewing port uses a 3.5 mm (0.18 in.) audio stereo jack connector. Table 12 lists the characteristics of the stereo port.

Table 12 Stereo Output Characteristics

Pin	Signal	Characteristics
Tip	Not connected	Reserved
Ring	Stereo output	Standard TTL into a 10 k Ω load
Sleeve	Common	Common

Appendix C — Cabling Information

Cable Information

Table 13 lists the cable that you can use with the PBXGB-AA/CA graphics option modules.

Table 13 Cable Options

Designation	Order Number	Length
BC13L-10	30-34761-03	3 meters (10 feet)

Appendix D — For Digital Service Use

Introduction The information in this section is for Digital service representatives.

FRU/Order Numbers See Table 14 to order field replaceable units (FRUs) for the customer.

Table 14 Module FRUs

FRU	Order Number
PBXGB-AA module	54-23481-01
PBXGB-CA module	54-23483-01
Antistatic wriststrap	12-36175-01
Snapon ferrite bead	16-25105-18

Index

C

- Cable options, 22
- Conventions
 - used in this guide, 2

F

- Frequency switch
 - description of, 7
- FRUs
 - order numbers for, 23

I

- Installation
 - confirmation of, 15
 - figure of, 12, 13
 - step-by-step, 9
 - troubleshooting problems, 15

M

- Modules
 - description of, 3
 - figure of 16 MB option, 6
 - figure of 2 MB option, 5
 - installation limitations, 4
 - software compatibility, 4
 - version, 3

O

- Overview
 - conventions used, 1
 - purpose of document, 1

P

- Problems
 - suggestions for solving, 15

S

- Service information
 - for Digital service representative, 23
 - FRU order numbers, 23
- Specifications
 - environmental, 20
 - hardware, 20
 - physical, 20
 - power consumption, 20
 - stereo output, 21
 - video output, 21
- Stereo cable
 - use with graphics option, 16
- Stereo monitor
 - use with graphics option, 16
- Stereo viewing
 - description of, 16
 - stereo cable, 16
- Switch
 - frequency, 7

Switch settings
 see PBXGB-AA/CA graphics option
 module, 7
 see Table 7, 17
 see Table 8, 17

T

Troubleshooting

installation problems, 15

V

Version

 of modules, 3

VGA

 2 MB option, 11

 16 MB option, 11

How to Order Additional Documentation

Technical Support

If you need help deciding which documentation best meets your needs, call 800-DIGITAL (800-344-4825) and press 2 for technical assistance.

Electronic Orders

If you wish to place an order through your account at the Electronic Store, dial 800-234-1998, using a modem set to 2400- or 9600-baud. You must be using a VT terminal or terminal emulator set at 8 bits, no parity. If you need assistance using the Electronic Store, call 800-DIGITAL (800-344-4825) and ask for an Electronic Store specialist.

Telephone and Direct Mail Orders

From	Call	Write
U.S.A.	DECdirect Phone: 800-DIGITAL (800-344-4825) Fax: (603) 884-5597	Digital Equipment Corporation P.O. Box CS2008 Nashua, NH 03061
Puerto Rico	Phone: (809) 781-0505 Fax: (809) 749-8377	Digital Equipment Caribbean, Inc. 3 Digital Plaza, 1st Street Suite 200 Metro Office Park San Juan, Puerto Rico 00920
Canada	Phone: 800-267-6215 Fax: (613) 592-1946	Digital Equipment of Canada Ltd. 100 Herzberg Road Kanata, Ontario, Canada K2K 2A6 Attn: DECdirect Sales
International	-----	Local Digital subsidiary or approved distributor
Internal Orders ¹ (for software documentation)	DTN: 264-3030 (603) 884-3030 Fax: (603) 884-3960	U.S. Software Supply Business Digital Equipment Corporation 10 Cotton Road Nashua, NH 03063-1260
Internal Orders (for hardware documentation)	DTN: 264-3030 (603) 884-3030 Fax: (603) 884-3960	U.S. Software Supply Business Digital Equipment Corporation 10 Cotton Road Nashua, NH 03063-1260

¹Call to request an Internal Software Order Form (EN-01740-07).

Reader's Comments

PBXGB-AA/CA PCI Graphics Option
Owner's Guide

EK-PCIGR-OG. A01

Your comments and suggestions help us improve the quality of our publications.

Thank you for your assistance.

I rate this manual's:	Excellent	Good	Fair	Poor
Accuracy (product works as manual says)	<input type="checkbox"/>	<input type="checkbox"/>	<input type="checkbox"/>	<input type="checkbox"/>
Completeness (enough information)	<input type="checkbox"/>	<input type="checkbox"/>	<input type="checkbox"/>	<input type="checkbox"/>
Clarity (easy to understand)	<input type="checkbox"/>	<input type="checkbox"/>	<input type="checkbox"/>	<input type="checkbox"/>
Organization (structure of subject matter)	<input type="checkbox"/>	<input type="checkbox"/>	<input type="checkbox"/>	<input type="checkbox"/>
Figures (useful)	<input type="checkbox"/>	<input type="checkbox"/>	<input type="checkbox"/>	<input type="checkbox"/>
Examples (useful)	<input type="checkbox"/>	<input type="checkbox"/>	<input type="checkbox"/>	<input type="checkbox"/>
Index (ability to find topic)	<input type="checkbox"/>	<input type="checkbox"/>	<input type="checkbox"/>	<input type="checkbox"/>
Page layout (easy to find information)	<input type="checkbox"/>	<input type="checkbox"/>	<input type="checkbox"/>	<input type="checkbox"/>

I would like to see more/less _____

What I like best about this manual is _____

What I like least about this manual is _____

I found the following errors in this manual:

Page	Description
_____	_____
_____	_____
_____	_____

Additional comments or suggestions to improve this manual:

For software manuals, please indicate which version of the software you are using: _____

Name/Title _____ Dept. _____

Company _____ Date _____

Mailing Address _____

Phone _____

Do Not Tear - Fold Here and Tape

digital™

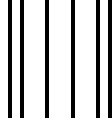

No Postage
Necessary
If Mailed
in the
United States

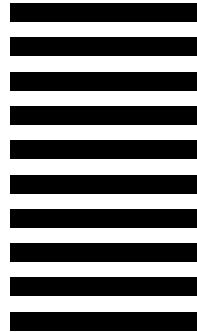

BUSINESS REPLY MAIL
FIRST CLASS PERMIT NO. 33 MAYNARD MASS.

POSTAGE WILL BE PAID BY ADDRESSEE

DIGITAL EQUIPMENT CORPORATION
Shared Engineering Services
DIGITAL DRIVE MKO1-2/E12
PO BOX 9501
MERRIMACK, NH 03054-9982



Do Not Tear - Fold Here