

# VMIVME-2210\* Specifications

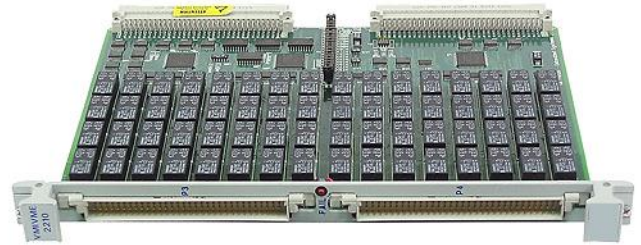

## 64-Channel Latching or Momentary Relay Board with Built-in-Test

### Features:

- Latching contacts will hold their state with power off
- Available in latching and nonlatching versions
- 1 Form C contacts (SPDT) with 96-conductor cable
- 1 Form A contacts (SPST) with 64-conductor cable
- 8-, 16-, or 32-bit data transfers
- Supports real time and offline fault detection and isolation
- 2.0A current rating
- Protection from relays changing during power up/down

Ordering Options			
July 18, 2012 800-002210-000 L	A	B	C
VMIVME-2210	-		

**A = Relay Type**

0 = Latching Relays  
1 = Nonlatching Relays

**B = Number of Channels**

0 = 64-Channel  
1 = Reserved

**C = Front Connector Type**

0 = 96-pin Nonlatching Connector, SPDT (See Note 1)  
1 = 64-pin Latching Connector, SPST

Recommended Connector Components for Cabling to P3 and P4		
Style	Description	I/O Connectors
64-pin IDC	Mating Connector (64-pin)	Panduit 120-964-435
	Strain Relief (for 64-pin connectors)	Panduit 100-000-072
96-pin IDC	Mating Connector (96-pin Mass Terminated)	ERNI No. 913.031
	0.033-inch Ribbon Cable (96-pin Mass Terminated)	ERNI No. 913.049
96-pin Discrete Wire	Mating Connector (96-pin Discrete)	Harting No. 09 03 096 3214
	Female Crimp Contacts (96-pin Discrete)	Harting No. ( See Note 2) 09 02 000 8484
	Connector Shell Housing (96-pin Connectors)	Harting No. 09 03 096 0501
	PC Board Connector Part Number	ERNI No. 913.216

**Notes**

1. Latches are located on the cable
2. The Harting crimp tool part number is 09 99 000 0075.

Refer to connector specifications and cable conductor size for current carrying capacity.

For Ordering Information, Call:  
1-800-322-3616 or 1-256-880-0444 • FAX (256) 882-0859  
Email: [info.embeddedsystems.jp@ge.com](mailto:info.embeddedsystems.jp@ge.com)  
Web Address: [www.ge-ip.com](http://www.ge-ip.com)

Copyright © 2012 GE Intelligent Platforms Embedded Systems, Inc.  
All Rights Reserved.  
Specifications subject to change without notice.

## Functional Characteristics

**Introduction:** The VMIVME-2210\* provides 64 One Form C (SPDT) contacts to the user via two 96-pin DIN connectors. These relays are the magnetic latching type which means that, once a contact is set it will remain set (even if power is removed from the relay) until it is reset. All three contact points are brought out via the connector. They are the N.O. (Normally Open), N.C. (Normally Closed), and the Common contact points. The N.O. and the Common can be used to create One Form A contacts while the N.C. and common can be used as One Form B contacts. The N.O. contacts are on Row A of the connectors and the common contacts are on Row C of the connector as shown in Figure 1. This arrangement permits 64-conductor cables to be used for Form A switches.

The VMIVME-2210 is populated with double pole relays, but only one pole is brought out to the user. The other pole is used by the Built-in-Test (BIT) logic. The state of the controlling Data Registers or the N.C. poles is read during read accesses of the board. The Control Registers are located at the same address as the relays. This allows

the user to monitor both the state of the user contacts and the Control Registers. Because the read pole and the user's pole are controlled by the same coil, BIT can monitor the user's contacts via the N.C. contacts of the second pole.

The N.C. contacts provide a logic one from the contacts for a logic one written to the Data Register. This provides positive data feedback from the contact BIT logic. When a logic one is written to the Control Register, it activates the relay which causes the N.O. contacts to close and the N.C. contacts to open. When the contact BIT logic is read, a logic one is returned.

The Control Data Registers are also monitored because the relays take a long time (7ms maximum) to change their contacts. VME accesses of the board can execute so quickly the relays seem to be faulty resulting in erroneous conclusions. To prevent this, the user can check the Data Register's state, instead of waiting for the relay's contacts to close.

This board uses latching relays which hold their state when power is removed. This means that closed contacts stay closed until commanded to open.

**Board Functions:** Sixty-four one Form C latching relay contacts via two 96-pin DIN connectors. One extra set of contacts (the N.C. set) is used for BIT. Latching relays hold their state (even with power removed) until commanded to change.

**Compliance:** The VMIVME-2210 conforms to the ANSI/IEEE STD 1014-1987 IEC 821 and 297 VMEbus specification with the following mnemonics: A24, A16: 3D/39, 2D/29: D32, D16, D08(E0): Slave.

**Addressing Scheme:** The base address of this board contains the board ID. Stacked above this 16-bit word is a 16-bit CSR. The Output Registers are placed at the next longword boundary above the CSR. Finally, the Contact Registers are stacked above the Output Registers. The Output and the Contact Registers are addressable as sixteen 8-bit bytes, eight 16-bit words, or four 32-bit longwords, located on any 128-bit boundary within standard data or short supervisory or nonprivileged I/O space.

**Board Addressing:** Twenty jumpers are used to select the base address of the board. One jumper determines the address space (standard data or short I/O) of the board. Another chooses supervisory, nonprivileged, or either access mode. And the remaining 18 set up the base address of the board.

**Built-in-Test:** Board testing is accomplished by performing a read operation. Reading the address of the relay in question will place the state of its Data Register on the bus. Reading the Contact Register transfers the state of the second N.C. contact to the bus. Both the data controlling the relay and the contact state can now be compared. This is done because the relay takes so long (7 ms maximum) to change its state. With this information, the user can determine when the relay contacts have changed state.

**Nonlatching Option:** If the nonlatching option is ordered, then standard relays are used. The contact data is not affected. However, the contacts will NOT hold when power is interrupted. This option will permit resets and power loss to place the relays in their normal position. Thus, N.O. contacts will open and the N.C. contacts will close. All other board operations are the same as those for the latching version.

## Output Characteristics

**Contact Material:** Silver alloy (Gold clad)

**Maximum Switching Voltage:** 220VDC, 250VAC resistive load

**Maximum Switching Current:** 2A DC, AC resistive load

**Switching Power:** 60W or 125VA resistive

**Initial Contact Resistance:** 50mW (by voltage drop 6VDC 1A)

**Contact Connect Times - Opening or Closing:** 6.5ms maximum with .5ms typical bounce time

**Dielectric Strength:** 750VAC, 50/60 Hz for 1 minute between contacts of the same pole

**Surge Withstand Voltage:** Conforms to Part 68 of FCC Regulations

**Service Life:** 5 x 10<sup>5</sup> minimum operations at rated current

## Physical/Environmental Specifications

**Dimensions:** 6U double slot Eurocard form factor

Height	9.2 in. (233.4mm)
Depth	6.3 in. (160mm)
Thickness	0.8 in. (20.3mm)

**Power Requirements:** +5VDC (±5 percent), 4A maximum

### Temperature:

Operating: 0 to +55° C

Storage: -20 to +85° C

**Relative Humidity** – 20% to 80%, noncondensing

**Cooling:** Forced air convection

**Output Connector:** Two front panel mounted 96-pin DIN connectors

**MTBF:** Contact Factory

## Trademarks

\* indicates a trademark of GE Intelligent Platforms, Inc. and/or its affiliates. All other trademarks are the property of their respective owners.

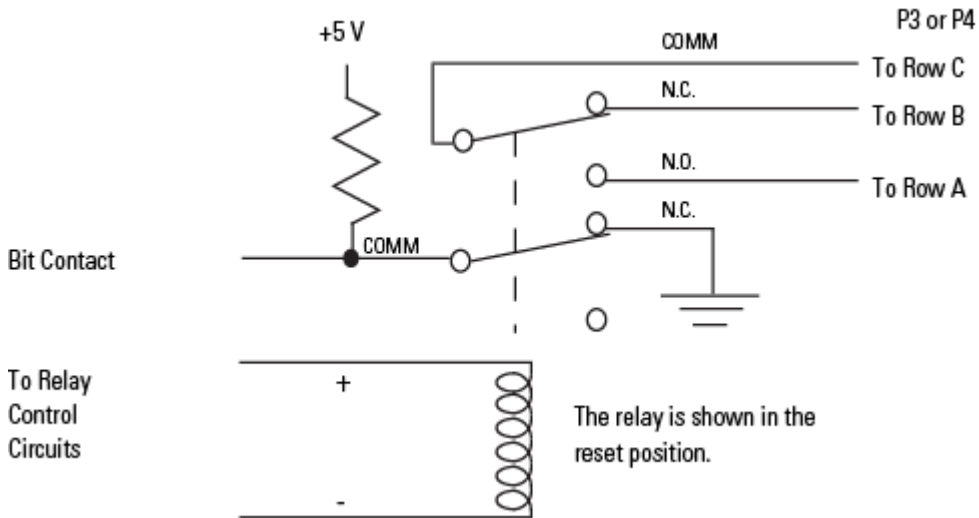

Figure 1. A Typical Relay Circuit



GE Intelligent Platforms  
Information Centers

Americas:  
1 800 322 3616 or 1 256 880 0444

Asia Pacific:  
86 10 6561 1561

Europe, Middle East and Africa:  
Germany +49 821 5034-0  
UK +44 1327 359444

Additional Resources

For more information, please visit the  
GE Intelligent Platforms Embedded Systems  
web site at:

[www.ge-ip.com](http://www.ge-ip.com)